

# ByteCOOL

27-300 kW



## Contents

1. About the company .....	02
2. General information .....	03
3. Product range .....	05
4. Product components .....	06
5. Precision air conditioners .....	07
6. Cooling systems .....	09
7. Specifications .....	17
8. Basic configuration .....	25
9. Options .....	27
10. Low-temperature modules .....	29
11. Dimensions (air conditioners) .....	30
12. Remote condensers .....	36
13. Specifications .....	37
14. Dimensions (remote condensers) .....	39



Felzer is one of the leading manufacturers of equipment and integrated solutions for HVACR systems (heating, ventilation, air conditioning and refrigeration) in Europe.

In our factories, we create safe and reliable equipment that maintains a comfortable microclimate and supports enterprise production processes.

Our in-house designing service, a wide range of options and flexible production facilities allow producing equipment in full compliance with the project requirements.

We guarantee uninterrupted operation of the equipment due to the use of European components, compliance with European standards and quality control of our products.

Felzer service center personnel perform commissioning and installation, provide warranty and post-warranty services and prompt technical support.



FELZER.LV



ByteCOOL precision air conditioners are a highly efficient solution for silent and precise control of the microclimate.

## 374 MODELS

ByteCOOL equipment line makes enables cooling of entire buildings or individual rooms in different ways, depending on the customer conditions and requirements.

Configuration options for precision air conditioners of this line can include such systems where the air is cooled by water in a heat exchanger (CW), or by

freon direct expansion in a heat exchanger (DX) and a mixed type systems.

The flexibility of configurations allows choosing the optimal option that fully meets the requirements on site.

### KEY ADVANTAGES:

- Maximum cooling capacity with minimum footprint
- Efficient air flow distribution in compliance with ASHRAE recommendations
- Usage of only high-quality components that can be serviced
- Energy-efficient solutions owing to the use of inverter compressors and free-cooling technology
- Low-noise cooling
- Long service life
- The compact design ensures convenience during transportation and installation.

## ByteCOOL precision air conditioner line



### BYTECOOL line

- **Configurations** with air supply down (D) or up (U);
- **12 standard sizes** with various cooling capacities;
- **Four configurations:**
  - DXR air conditioner is a compressor system with direct expansion with a remote condenser;
  - DXW air conditioner is a compressor system with cooling by direct expansion with a water cooling condenser;
  - DXE air conditioner is a compressor-free system with cooling by direct expansion that works with an air compressor condensing unit;
  - CW air conditioner is a cooling system by the chilled water from the chiller.
- **Compressors** with fixed rotation speed or adjustable rotation speed, that is, with an inverter;
- **Choice of refrigerant:** R410A, R507A, R454B, R32, R407C, R134a;
- **Freestanding (cabinet) and in-row** models;
- **A wide range of options**, including winter start-up at the temperature of to -35 °C, free-cooling, heating, humidification, air dehumidification, and more.



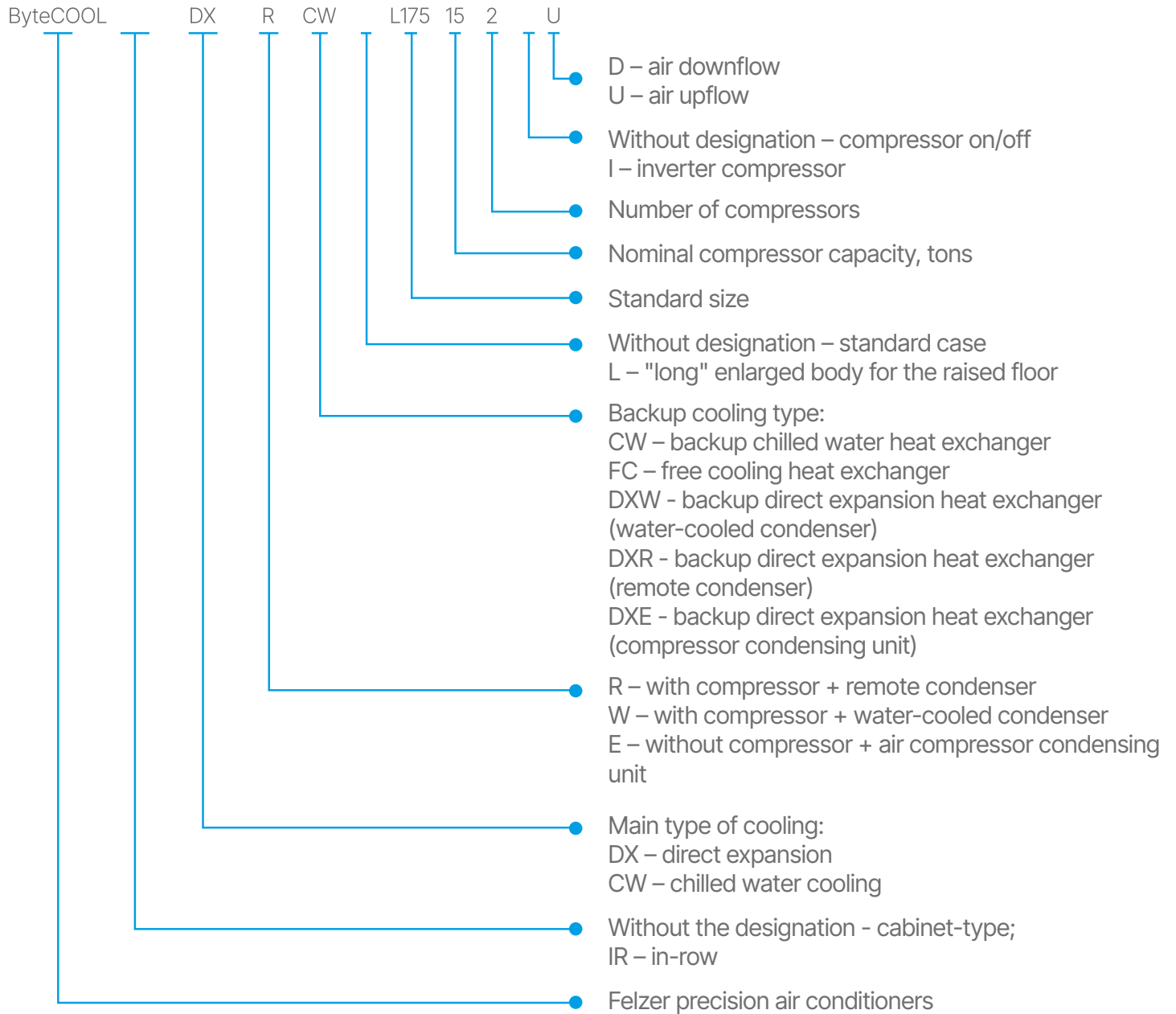



### HOUSING

Precision air conditioners have a housing that is made of galvanized sheet steel. It is powder-coated to protect it from weather conditions. The inside of the housing is lined with panels with heat- and soundproof material.

### COMPRESSORS

Scroll compressors from the world's leading manufacturers are installed in the air conditioners. The frequency converter is available for all standard sizes.

### HEAT EXCHANGERS

Copper-aluminum air coolers have a large heat exchange area. The heat exchangers have with stainless steel trays with a flexible condensate drain pipe.

### FANS

Air conditioners come standard with electronically commutated (EC) fans, which allow for adjustable fan speed over a wide range, enabling operation with varying airflows and static pressure levels.

### FILTERS

G4 filter is a standard option. In addition, various filter options with a higher filtration class are available.

### COMPONENTS OF THE CONTROL SYSTEM

- The electrical panel has a main switch. The secondary circuit is powered by a low voltage of 24 V. Various power supply options are available, depending on the requirements for air conditioning equipment.
- The latest generation controller ensures safe and efficient operation of the refrigeration circuit, air supply control and maintaining pressure.
- Air conditioners can be provided with displays of various sizes and functions. Controllers can support Modbus, SNMP, Lonworks, Bacnet (and others) protocols. Due to this, air conditioners can be easily integrated into the automated building management system (BMS).

### HUMIDIFIERS (OPTIONAL)

ByteCOOL precision air conditioners are equipped with CAREL steam humidifiers.

### HEATERS (OPTIONAL)

Optionally, efficient electric or water heaters can be provided in the air conditioner.

## CABINET TYPE

BUILT-IN FAN



TOP AIR INTAKE, CONDITIONING UNDER THE RAISED FLOOR OR FORWARD THROUGH THE PLENUM

Since hot air accumulates under the ceiling of the room, and cold air accumulates at the bottom of the room, the most natural supply of cooled air is from top to bottom.

The cabinet type of the ByteCOOL precision downstream air conditioner is an ideal option for rooms with low and medium density of server equipment in mounting racks. If there is a raised floor, the air supply under the raised floor is optimal. If there is no raised floor, it is possible to use a plenum to supply air in any desired direction.

## CABINET TYPE

BUILT-IN FAN



FRONT AIR INTAKE FROM THE FRONT, AIR UPFLOW

If the cooled space lacks a raised floor and does not have sufficient height for a plenum base, or if cold air is distributed through ductwork installed near the ceiling, then front-intake, top-discharge cabinet air conditioners are recommended.

## CABINET TYPE

FANS UNDER THE RAISED FLOOR



TOP AIR INTAKE, BLOWING UNDER THE RAISED FLOOR OR FORWARD (FRONTAL)

An external fan unit located under the air conditioner in a raised floor or plenum. The space freed up by removing the fans allows for the installation of larger heat exchangers, significantly increasing cooling capacity per unit area. The placement of fans in the raised floor reduces turbulence and deflects the direction of air flow. As a result, perfect air circulation is achieved, which significantly reduces the power consumption of the fan.

## IN-ROW AIR CONDITIONERS



ByteCOOL In-row precision air conditioners are installed directly between the mounting racks in the server rooms. Due to the horizontal intake and air supply, the cooled air flows directly into the server racks, forming a cold air curtain in front of them. Such solutions allow for cooling high-density server racks. Also, the in-row air conditioners are compatible with various isolated corridors.

## NON-REDUNDANT

Felzer implements various configurations of precision air conditioners. The most common cooling system solutions are described in this section.

**DX (direct expansion):** The air is cooled by evaporation of the refrigerant in the vapor compression circuit evaporator.

Precision air conditioners of the DX series are designed and manufactured specifically for servicing areas that are not provided with cooling system using chilled water (liquid) from chillers. Both fixed-speed compressors and variable-speed inverter compressors are available for DX systems.

## DXR(I)-D(U)

SERIES

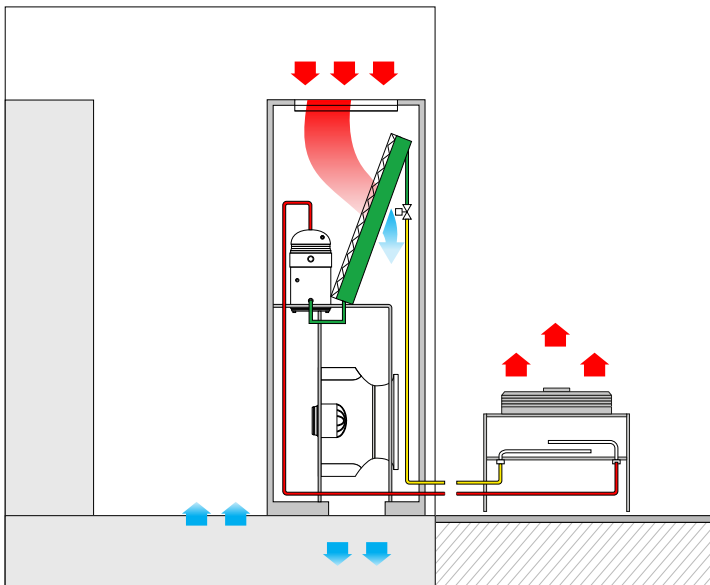

## AIR CONDITIONERS WITH REMOTE CONDENSER

This configuration of a precision air conditioner with a remote condenser consists of two units (indoor and outdoor). Accordingly, the indoor unit is installed indoors, and the outdoor unit, the condenser, is installed outside for air cooling.

The classical steam compression cycle is implemented in this case. The air from the room is taken from the top, it passes through the evaporator and the cooled air is distributed through the raised floor back into the room. In the evaporator, the boiling refrigerant absorbs heat from the air. The refrigerant vapor is then drawn into the compressor, where it is compressed and discharged to the condenser.

The refrigerant vapors in the remote condenser are cooled by the ambient air and change their gaseous state to a liquid state.

It is necessary to install copper pipes for connecting the remote condenser to the indoor unit and to fill the air conditioner with refrigerant after installation. Air conditioners can operate independently or as part of a group (master-slave).

## DXW(I)-D(U)

SERIES

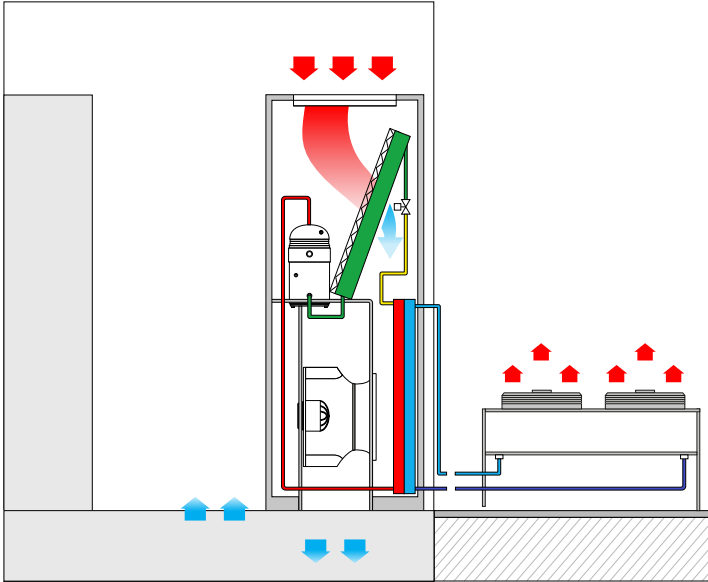

### AIR CONDITIONER WITH WATER-COOLED CONDENSER

Unlike DXR series precision air conditioners with a remote condenser, the DXW series has a built-in condenser that is cooled with water or a non-freezing liquid. Thus, the entire refrigeration circuit is located inside one unit. In this case, the air conditioner is supplied with a charged refrigerant. The heat from the condenser is removed by the liquid. This liquid is cooled in a cooling tower or in a dry cooler. One dry cooler or cooling tower can be used for a group of DXW series air conditioners with a water-cooled condenser.

## DXE(I)-D(U)

SERIES

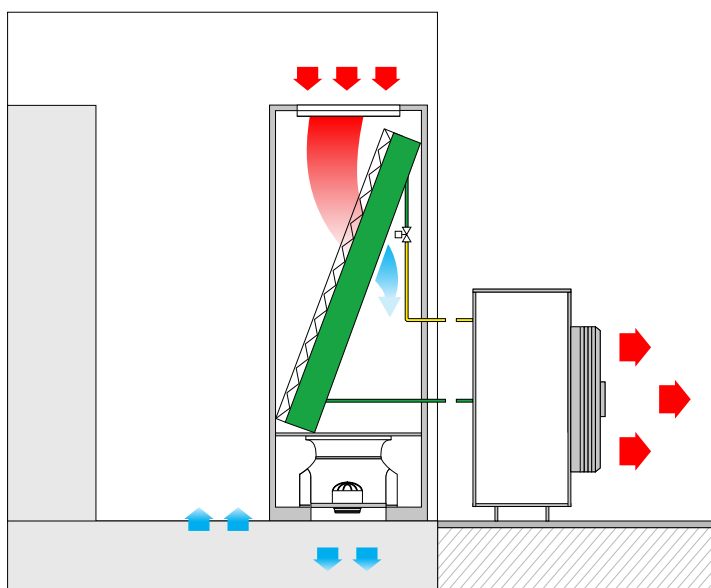

### AIR CONDITIONER WITH AIR COMPRESSOR CONDENSING UNIT

Precision air conditioners of the DXE series cool the indoor air employing a steam compression cycle. This unit has a heat exchanger for direct expansion of the refrigerant inside the air conditioner housing, to which the air compressor condensing unit is connected. The air compressor condensing unit is installed outdoors in a place with a good air circulation. To reduce the loss of cooling capacity due to the length of the route, it is recommended to install the unit as close as possible to the indoor unit.

## CW

SERIES

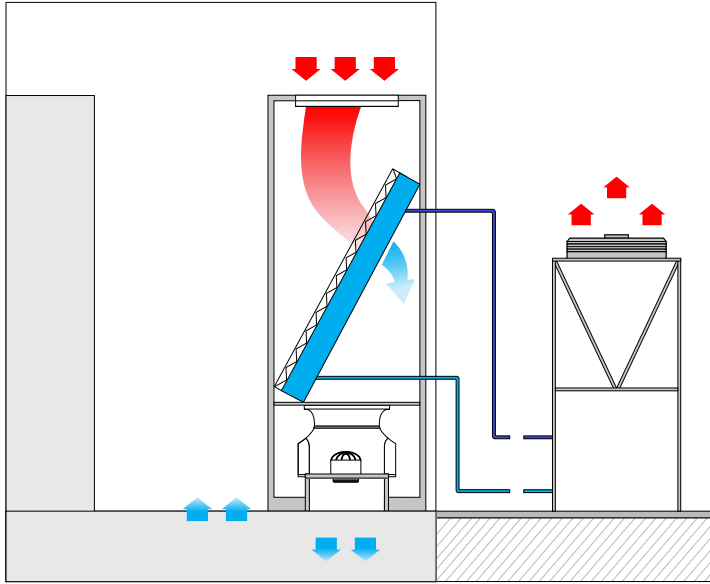

## AIR CONDITIONERS WITH A LIQUID HEAT EXCHANGER

The CW series air conditioners do not have their own refrigeration circuit and compressors. The warm indoor air passes through the heat exchanger of the CW air conditioner, which cools it due to chilled water (non-freezing liquid). The CW series air conditioners can use the cooled liquid from both the chiller and the dry cooler, in the "free-cooling" mode. The air conditioner unit and the chiller or dry cooler are connected by a closed loop of water circulation with glycol.

## COOLING SYSTEMS WITH FREE COOLING

Free-cooling is a solution that makes it possible to cool rooms during the cold season without using a steam compression cycle directly due to the lower ambient temperature. With free cooling, the system consumes little electricity, only to power the fans and pumps, compared to running compressors. "Free cooling" means free of charge cooling.

### Precision air conditioners with mixing chamber

Felzer has developed a special solution for small and medium-sized data centers: a precision air conditioner with a Free Cooling Plenum (FCP) mixing chamber.

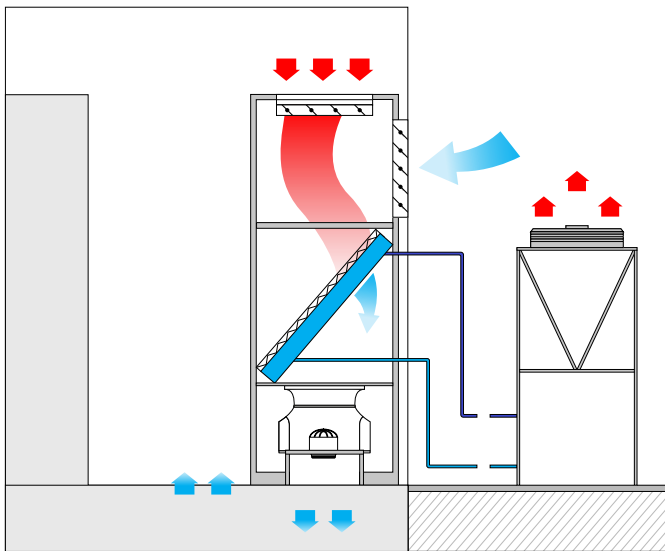

ByteCOOL cabinet air conditioners with air downflow can be equipped with a Free Cooling Plenum mixing chamber to harness the vast potential of outdoor air temperature for energy savings even in small data centers or during cooling system upgrades. The cooling chamber utilizes cold outdoor air, which passes through the air conditioner's filter before entering the room. Due to the overpressure created in the room, part of the hot air is exhausted outside through additional ventilation ducts.

When "free cooling plenum" option is used, the air is further cooled by a steam compression cycle.

The air conditioner with the "free cooling plenum" option can operate in three modes. This solution reduces power consumption and increases the service life of compressors.

Three modes of operation of the air conditioner with a mixing chamber:

1. Free cooling mode only:

- The flap opens and the outside air is supplied;
- The outside air passes through the filter of the "Free Cooling Plenum" chamber directly into the air conditioner, and then is distributed to the cooled room.
- The steam compression cycle is switched off. The power consumption is minimal in this mode;
- If the outside temperature is too low, the outside air is mixed with the return air to ensure the desired temperature.

2. Mixed cooling mode:

In the mixed cooling mode, free cooling and refrigeration power from the steam compression cycle are used. In this case, the compressor cycle operates at partial load, thereby reducing the Customer's power consumption.

3. Steam compression mode:

- The air conditioner is cooled solely by a steam compression cycle;
- The outside air flap is closed, the outside air is not used for cooling;
- The return air valve is open at 100 %;

The drawbacks of this free-cooling chamber solution include the introduction of outdoor air, which not only contaminates the air conditioner filters but also reduces indoor humidity levels during winter. Depending on the equipment being cooled, this may necessitate installing humidifiers, preparing water for them, and incurring other associated costs. In this regard, other "free-cooling" mode solutions are also available in ByteCOOL air conditioners.

## CW

SERIES

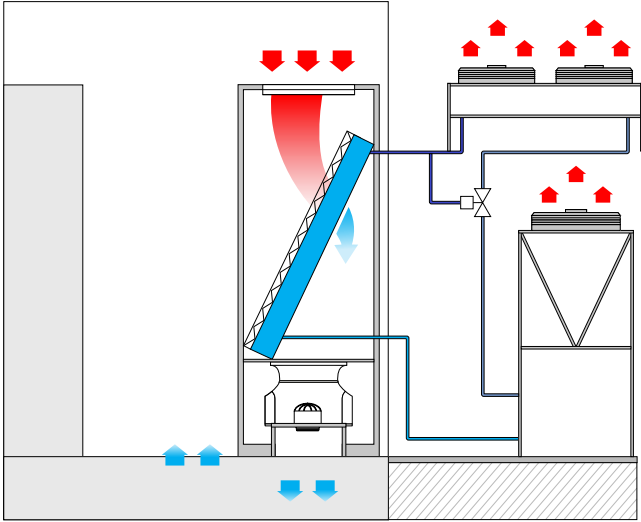

## INDIRECT FREE-COOLING BASED ON CW AIR CONDITIONERS (USING COLD LIQUID)

Indirect free-cooling is implemented by connecting CW air conditioners (chilled water heat exchanger) to Felzer chillers equipped with a free-cooling system, or to a combination of Felzer chillers and Felzer NordGALE dry coolers.

This system delivers up to 60% energy savings while completely isolating indoor air from outdoor air. This not only reduces the need for air humidification and filter load but also minimizes equipment failure risks, ensuring continuous cooling system operation with minimal power consumption.

## DXW FC

SERIES

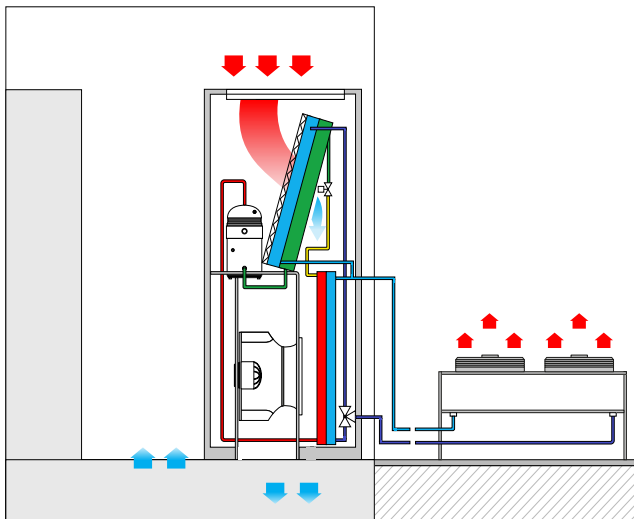

## INDIRECT FREE-COOLING BASED ON DXW FC SERIES AIR CONDITIONERS

Unlike the CW air conditioner system (with a water-to-air heat exchanger), the DXW FC air conditioner system does not require the use of a chiller, but only works with a dry cooler. The air conditioner already has a built-in steam compression cycle, and the system operates in the same way in the compressor mode as the DXW series air conditioner. But unlike it, the DXW FC system is additionally provided with a built-in free-cooling heat exchanger. Thus, during the cold season, energy-intensive compressor cooling can be fully or partially suspended. The chilled water (non-freezing liquid) supplied from the dry cooler into the condenser cooling circuit is redirected to the additional heat exchanger of the DXW FC air conditioner.

In full free-cooling mode, all heat is removed by an additional free cooling heat exchanger and then discharged into the environment through a dry cooler.

## WITH REDUNDANCY

ByteCOOL redundant air conditioners have independent operating and backup cooling circuits. The basic liquid cooling, similar to the CW system, is complemented by a second cooling system that is connected in case of problems. It is recommended to install such air conditioners in data centers with high requirements for the performance of the cooling system.

In full free-cooling mode, all heat is removed by an additional free cooling heat exchanger and then discharged into the environment through a dry cooler.

## CW DXR

SERIES

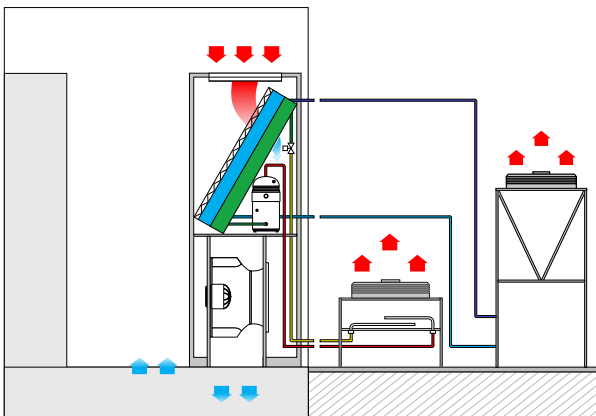

## COOLING WITH CHILLED WATER (CW) AND REFRIGERANT (DXR-AIR CONDITIONER WITH REMOTE CONDENSER)

Two independent cooling circuits, CW and DXR, are provided in one air conditioner unit, which ensures reliable protection from possible failures. The compressor system (DXR) with an remote condenser guarantees uninterrupted air conditioning in case of failure of the main liquid-cooled system (CW).

## CW DXW

SERIES

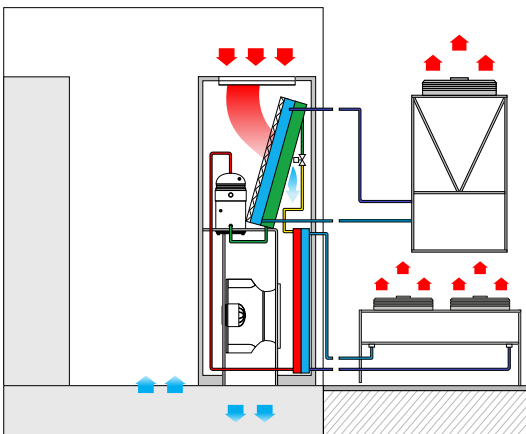

## COOLING WITH CHILLED WATER (CW) AND REFRIGERANT (DXW- AIR CONDITIONER WITH WATER-COOLED CONDENSER)

Two independent heat exchangers are provided in one unit of the air conditioner: the CW heat exchanger with chilled water and the DX heat exchanger with direct expansion of the refrigerant.

The CW system is complemented by a liquid-cooled condenser DXW system. Thus, the main system is based on chillers, while the backup system is based on dry coolers.

## CW CW

SERIES

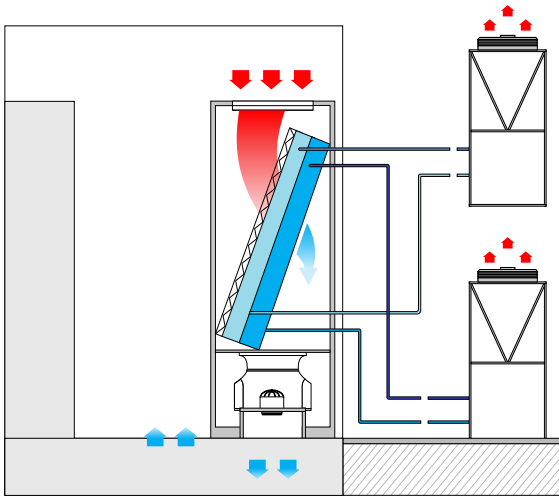

### CHILLED WATER COOLING CW/CW

The air conditioner is designed to work with two independent liquid cooling systems based on chillers and/or dry coolers.

## CW DXE

SERIES

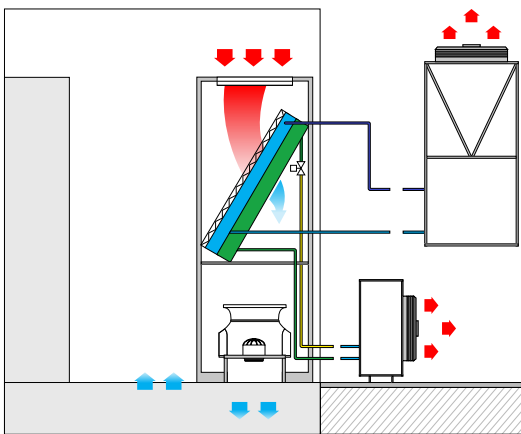

### COOLING WITH WATER (CW) AND REFRIGERANT (DXE – AIR CONDITIONER WITH AIR COMPRESSOR CONDENSING UNIT)

The precision air conditioner has two independent cooling circuits in this configuration. One circuit (CW) is designed for cooling with water or liquid supplied from a chiller. Another cooling circuit (DXE) is a steam compression circuit, in which the air compressor condensing unit is installed outdoors.

Section 6 discusses the most common configurations of precision air conditioners. On request, Felzer can produce other configurations of air conditioners that are ideal for the facility.

ByteCOOL  
DXR(W)-U(D)PRECISION AIR CONDITIONERS WITH  
INTEGRATED COMPRESSOR

Type		In-row air conditioners			Cabinet air conditioners				
	Unit	IR300.061	IR400.081	IR600.101	S060.021	S085.031	S120.051	L085.051	L085.061
Total cooling capacity DXR(W*) "tair"=24°C, 50%, "tc" =45°C	kW	18.56	23.53	32.79	7.51	8.08	15.64	15.37	19.24
Total cooling capacity DXR(W*) "tair"=24°C, 50%, "tc"=50°C*	kW	18.17	22.2	32.11	30.81	7.61	17.76	14.51	18.1
Total cooling capacity DXR(W*) "tair"=35°C, 50%, "tc"=45°C	kW	23.08	28.22	39.96	9.05	9.89	18.62	18.62	23.48
Total cooling capacity DXR(W*) "tair"=35°C, 50%, "tc"=50°C	kW	22.03	26.97	38.28	8.68	9.48	17.8	17.83	22.43
Air flow rate	m <sup>3</sup> /h	4600	5400	8000	1720	1720	3210	3270	4380
Number of circuits/ compressors	pc./pc.	1/1	1/1	1/1	1/1	1/1	1/1	1/1	1/1
Depth	mm	1200/ 1400	1200/ 1400	1200/ 1400	449	449	449	865	865
Width	mm	300	400	600	600	850	1200	850	850
Height	mm	1950	1950	1950	1875	1875	1875	1970	1970
Power supply	V/ph/Hz	400/3/50	400/3/50	400/3/50	400/3/50	400/3/50	400/3/50	400/3/50	400/3/50
<b>DXW connections</b>									
Diameter of condenser pipe	inch	G1	G1	G1 $\frac{1}{4}$	G $\frac{1}{2}$	G $\frac{1}{2}$	G1	G1	G1
Operating weight of DXW	kg	240	270	330	235	185	210	335	335
<b>DXR connections</b>									
Diameter of the refrigerant discharge pipe	mm	16	19	22	12	12	16	16	16
Diameter of liquid refrigerant pipe	mm	12	16	16	10	10	12	12	12
DXR operating weight	kg	220	250	300	215	170	200	330	335
<b>Recommended condensers for DXR</b>									
Standard (Tcond=Tair+ 18K)	-	BN046	BN046	BN055	BN015	BN022	BN031	BN031	BN046
Increased (Tcond=Tair+ 15K)	-	BN055	BN055	BN070	BN022	BN024	BN046	BN046	BN055
Microchannel heat exchanger	-	MC17	MC18	MC18	MC15	MC15	MC17	MC17	MC17

\* - for DXW, the input/output water temperature in the condenser is 30/35°C

ByteCOOL  
DXR(W)-U(D)PRECISION AIR CONDITIONERS WITH  
INTEGRATED COMPRESSOR

Type		Cabinet air conditioners						
	Unit	L120.071	L140.091	L140.101	L175.121	L175.122	L175.131	L171.151
Total cooling capacity DXR(W*) "tair"=24°C, 50%, "tc"=45°C	kW	25.8	31.87	35.11	40.16	42.5	45.41	49.64
Total cooling capacity DXR(W*) "tair"=24°C, 50%, "tc"=50°C	kW	24.25	30.16	33.25	38.1	40.3	42.85	47.1
Total cooling capacity DXR(W*) "tair"=35°C, 50%, "tc"=45°C	kW	32.67	41.06	45.08	51.61	54.68	58.15	63.76
Total cooling capacity DXR(W*) "tair"=35°C, 50%, "tc"=50°C	kW	31.16	39.1	42.85	49.15	51.9	55	60.72
Air flow rate	m³/h	7000	10500	11000	12500	12500	14000	15000
Number of circuits/compressors	pc./pc.	1/1	1/1	1/1	1/1	2/2	1/1	1
Depth	mm	865	865	865	865	865	865	865
Width	mm	1200	1400	1400	1750	1750	1750	850
Height	mm	1970	1970	1970	1970	1970	1970	1970
Power supply	V/ph/Hz	400/3/50	400/3/50	400/3/50	400/3/50	400/3/50	400/3/50	400/3/50
<b>DXW connections</b>								
Diameter of the condenser pipe	inch	G1 $\frac{1}{4}$	G1 $\frac{1}{2}$	G2 $\frac{1}{2}$	G1 $\frac{1}{2}$	2 x G1	G1	G2
Operating weight of DXW	kg	360	475	475	560	585	560	560
<b>DXR connections</b>								
Diameter of the refrigerant discharge pipe	mm	19	19	19	22	2 x 16	22	22
Diameter of liquid refrigerant pipe	mm	16	16	16	16	2 x 12	16	16
DXR operating weight	kg	350	460	460	550	575	555	560
<b>Recommended condensers for DXR air conditioners</b>								
Standard (Tcond=Tair+ 18K)	-	BN046	BN055	BN070	BN075	2xBN046	BN083/ BN100	BN083/ BN100
Increased (Tcond=Tair+ 15K)	-	BN070	BN075	BN083/ BN100	BN083/ BN100	2xBN055	BN121	BN121
Microchannel heat exchanger	-	MC18	MC18	MC19	MC19	2KHM17	MC19	MC19

\* - for DXW, the input/output water temperature in the condenser is 30/35°C

ByteCOOL  
DXR(W)-U(D)PRECISION AIR CONDITIONERS WITH  
INTEGRATED COMPRESSOR

Type		Cabinet air conditioners						
	Unit	L175.152	L205.182	L255.202	L255.242	L255.262	L335.302	L335.402
Total cooling capacity DXR(W*) "tair"=24°C, 50%, "tc"=45°C	kW	50.88	61.66	69.1	76.1	87.7	98.99	128.66
Total cooling capacity DXR(W*) "tair"=24°C, 50%, "tc"=50°C	kW	47.98	58.22	65.17	73.36	82.6	92.41	120.82
Total cooling capacity DXR(W*) "tair"=35°C, 50%, "tc"=45°C	kW	65.02	79.42	88.12	98.9	109.72	124.44	157
Total cooling capacity DXR(W*) "tair"=35°C, 50%, "tc"=50°C	kW	61.84	75.77	83.8	94.52	104.62	118.52	143.5
Air flow rate	m <sup>3</sup> /h	15000	20000	20000	23000	24500	27000	32000
Number of circuits/compressors	pc./pc.	2/2	2/2	2/2	2/2	2/2	2/2	2/2
Depth	mm	865	865	865	865	865	865	865
Width	mm	1750	2050	2550	2550	2550	3350	3350
Height	mm	1970	1970	1970	1970	1970	1970	1970
Power supply	V/ph/Hz	400/3/50	400/3/50	400/3/50	400/3/50	400/3/50	400/3/50	400/3/50
<b>DXW connections</b>								
Diameter of the condenser pipe	inch	2 × G1 $\frac{1}{4}$	2 × G1 $\frac{1}{4}$	2 × G1 $\frac{1}{4}$	2 × G1 $\frac{1}{4}$	2 x G2	2 x G2	2 x G2
Operating weight of DXW	kg	590	745	860	860	860	940	940
<b>DXR connections</b>								
Diameter of the refrigerant discharge pipe	mm	2×16	2×19	2×19	2×22	2×22	2×22	2×22
Diameter of liquid refrigerant pipe	mm	2×16	2×16	2×16	2×16	2×16	2×16	2×22
DXR operating weight	kg	580	710	830	833	385	910	914
<b>Recommended condensers for DXR air conditioners</b>								
Standard (Tcond=Tair+ 18K)	-	2xBN046	2xBN055	2xBN070	2xBN075	2xBN083/ BN100	2xBN083/ BN100	BN083/ BN100+BN121
Increased (Tcond=Tair+ 15K)	-	2xBN070	2xBN075	2xBN083/ BN100	2xBN083/ BN100	2xBN121	2xBN121	BN121 +BN140
Microchannel heat exchanger	-	2KHMX18	2KHMX18	2KHMX19	2KHMX19	2KHMX19	2KHMX201	MC201 +MC202

\* - for DXW, the input/output water temperature in the condenser is 30/35°C

## ByteCOOL DXR(W)I-U(D)

## PRECISION AIR CONDITIONERS WITH BUILT-IN INVERTER COMPRESSOR

Type		In-row air conditioners			Cabinet precision air conditioners			
	Unit	IR300.05i	IR400.07i	IR600.09i	L085.04i	L085.05i	L120.07i	L140.09i
Total cooling capacity DXR(W*) "tair"=24°C, 50%, "tc"=45°C	kW	18.8	23,56	32.86	1712	20.65	26.55	31.87
Total cooling capacity DXR(W*) "tair"=24°C, 50%, "tc"=50°C	kW	17.98	22.26	31.18	16.26	19.65	25.12	30.16
Total cooling capacity DXR(W*) "tair"=35°C, 50%, "tc"=45°C	kW	22.89	28.76	39.96	21.92	26.56	33.46	41.06
Total cooling capacity DXR(W*) "tair"=35°C, 50%, "tc"=50°C	kW	21.98	27.65	38,68	21.13	25.43	32.08	39.1
Air flow rate	m <sup>3</sup> /h	4600	5400	8000	5900	6500	7000	11000
Number of circuits/compressors	pc./pc.	1/1	1/1	1/1	1/1	1/1	1/1	1/1
Depth	mm	1200	1200	1200	865	865	865	865
Width	mm	300	400	600	850	850	1200	1400
Height	mm	1950	1950	1950	1970	1970	1970	1970
Power supply	V/ph/Hz	400/3/50	400/3/50	400/3/50	400/3/50	400/3/50	400/3/50	400/3/50
<b>DXW connections</b>								
Diameter of condenser pipe	inch	G1	G1	G1 $\frac{1}{4}$	G $\frac{3}{4}$	G1	G1 $\frac{1}{4}$	G1 $\frac{1}{2}$
Operating weight of DXW	kg	240	270	330	335	335	360	475
<b>DXR connections</b>								
Diameter of the refrigerant discharge pipe	mm	12	12	18	12	12	12	22
Diameter of liquid refrigerant pipe	mm	10	10	16	10	10	10	16
DXR operating weight	kg	220	250	300	330	336	350	460
<b>Recommended condensers for DXR air conditioners</b>								
Standard (Tcond=Tair+ 18K)	-	BN046	BN046	BN055	BN031	BN046	BN046	BN046
Increased (Tcond=Tair+ 15K)	-	BN055	BN055	BN070	BN046	BN055	BN070	BN070
Microchannel heat exchanger	-	MC17	MC18	MC18	MC17	MC17	MC18	MC18

\* - for DXW, the input/output water temperature in the condenser is 30/35°C

## ByteCOOL DXR(W)I-U(D)

### PRECISION AIR CONDITIONERS WITH BUILT-IN INVERTER COMPRESSOR

Type		Cabinet precision air conditioners						
	Unit	L175.111i	L175.102i	L175.131i	L175.132i	L255.172i	L255.171i	L255.222i
Total cooling capacity DXR(W*) "tair"=24°C, 50%, "tc"=45°C	kW	48.11	45.84	57.78	58.96	76.88	77.56	96.22
Total cooling capacity DXR(W*) "tair"=24°C, 50%, "tc"=50°C	kW	43.08	39.08	40	52	64.6	72.6	80
Total cooling capacity DXR(W*) "tair"=35°C, 50%, "tc"=45°C	kW	53.65	54	58.16	63.53	89.09	89.09	108.6
Total cooling capacity DXR(W*) "tair"=35°C, 50%, "tc"=50°C	kW	53.32	51.68	57.36	62.6	85.32	85.32	103.56
Air flow rate	m <sup>3</sup> /h	12500	12500	14000	15000	20000	20000	24500
Number of circuits/ compressors	pc./pc.	1/1	2/2	1/1	2/2	2/2	1/1	2/2
Depth	mm	865	865	865	865	865	865	865
Width	mm	1750	1750	1750	1750	2550	2550	2550
Height	mm	1970	1970	1970	1970	1970	1970	1970
Power supply	V/ph/Hz	400/3/50	400/3/50	400/3/50	400/3/50	400/3/50	400/3/50	400/3/50
DXR operating weight	kg	550	575	557	580	830	832	837
Operating weight of DXW	kg	560	585	563	590	860	865	861
<b>DXW connections</b>								
Diameter of condenser pipe	inch	G1 $\frac{1}{2}$	2 x G1	G1	2 x G1	2 x G1 $\frac{1}{4}$	2 x G1 $\frac{1}{4}$	2 x G1 $\frac{1}{4}$
<b>DXR connections</b>								
Diameter of the refrigerant discharge pipe	mm	22	2x12	22	2x12	2 x 22	22	2 x 22
Diameter of liquid refrigerant pipe	mm	16	2x10	16	2x10	2 x 16	16	2 x 16
<b>Recommended condensers for DXR air conditioners</b>								
Standard (Tcond=Tair+ 18K)	-	BN083 (BN100)	2xBN046	BN083 (BN100)	2xBN046	2xBN070	BN140	2xBN083 (BN100)
Increased (Tcond=Tair+ 15K)	-	BN121	2xBN055	BN140	2xBN070	2xBN083 (BN100)	2xBN083 (BN100)	2xBN121

\* - for DXW, the input/output water temperature in the condenser is 30/35°C

ByteCOOL  
DXR(W)I-U(D)PRECISION AIR CONDITIONERS WITH  
BUILT-IN INVERTER COMPRESSOR

Type		Cabinet air conditioners		
	Unit	L335.261i	L335.262i	L335.352i
Total cooling capacity DXR(W*) "tair"=24°C, 50%, "tc"=45°C	kW	101.6	103.99	133.84
Total cooling capacity DXR(W*) "tair"=24°C, 50%, "tc"=50°C	kW	95.38	98.3	126.35
Total cooling capacity DXR(W*) "tair"=35°C, 50%, "tc"=45°C	kW	157.25	129.3	161.72
Total cooling capacity DXR(W*) "tair"=35°C, 50%, "tc"=50°C	kW	122.13	124.32	155.28
Air flow rate	m³/h	27000	27000	32000
Number of circuits/compressors	pc./pc.	2/2	2/2	2/2
Depth	mm	865	865	865
Width	mm	3350	3350	3350
Height	mm	1970	1970	1970
Power supply	V/ph/Hz	400/3/50	400/3/50	400/3/50
<b>DXW connections</b>				
Diameter of condenser pipe	inch	2 x G2	2 x G2	2 x G2
Operating weight of DXW	kg	940	943	947
<b>DXR connections</b>				
Diameter of the refrigerant discharge pipe	mm	2 x 28	2 x 22	2 x 22
Diameter of liquid refrigerant pipe	mm	2 x 22	2 x 16	2 x 16
DXR operating weight	kg	910	913	917
<b>Recommended condensers for DXR air conditioners</b>				
Standard (Tcond=Tair+ 18K)	-	2xBN083 (BN100)	2xBN083 (BN100)	2xBN140
Increased (Tcond=Tair+ 15K)	-	2xBN121	2xBN140	4xBN083 (BN100)
Microchannel heat exchanger	-	MC202	2KHMx201	2KHMx201

\* - for DXW, the input/output water temperature in the condenser is 30/35°C

## ByteCOOL CW\* (DXE\*\*)-U(D)

## PRECISION AIR CONDITIONERS WITHOUT COMPRESSOR

\*CW - chilled water

\*\*DXE - operates with air compressor condensing unit

Type		In-row air conditioners			Cabinet air conditioners				
	Unit	IR300	IR400	IR600	S060	S085	S120	L085	L120
Total cooling capacity CW (DXE) "tai"=24°C, 50%, "tc"=7/12°C	kW	18.01	24.29	43.77	11.63	14.18	26.42	34.98	48.43
Total cooling capacity CW (DXE) "tai"=24°C, 50%, "tc"=7/12°C	kW	13.12	16.68	29.34	7.44	8.82	16.62	22.88	30.41
Total cooling capacity CW (DXE) "tai"=24°C, 50%, "tc"=7/12°C	kW	31.61	41.88	73.21	18.42	21.86	41.54	56.82	74.97
Total cooling capacity CW (DXE) "tai"=24°C, 50%, "tc"=7/12°C	kW	27.83	35.98	62.37	14.93	17.24	33.31	47.14	60.23
Air flow rate	m <sup>3</sup> /h	5000	6400	11200	2150	2500	5000	7500	9000
Depth	mm	1200	1200	1200	449	449	449	865	865
Width	mm	300	400	600	600	850	1200	850	1200
Height	mm	1950	1950	1950	1875	1875	1875	1970	1970
Operating weight	kg	170	195	250	150	180	240	300	360
Power supply	V/ph/Hz	400/3/50	400/3/50	400/3/50	400/3/50	400/3/50	400/3/50	400/3/50	400/3/50
<b>Connection dimensions</b>									
Diameter of the refrigerant suction pipe (DXE)	mm	22	28	35	18	18	22	22	28
Diameter of the liquid refrigerant pipe (DXE)	mm	15	16	18	12	12	12	15	15
Diameter of chilled water (CW)	inch	G1	G1	G1 $\frac{1}{4}$	G $\frac{3}{4}$	G $\frac{3}{4}$	G1	G1	G1

## ByteCOOL CW\* (DXE\*\*)-U(D)

## PRECISION AIR CONDITIONERS WITHOUT COMPRESSOR

\*CW - chilled water

\*\*DXE - operates with air compressor condensing unit

Type	Cabinet air conditioners					
	Unit	L140	L175	L205	L255	L335
Total cooling capacity CW (DXE) "tair"=24°C, 50%, "tc"=12/7°C	kW	54.86	77.09	100.77	142.72	167.27
Total cooling capacity CW (DXE) "tair"=24°C, 50%, "tc"=15/10°C	kW	34.8	44.99	63.62	89.78	107.4
Total cooling capacity CW (DXE) "tair"=35°C, 50%, "tc"=12/7°C	kW	87.07	127.4	157.48	217.44	273.64
Total cooling capacity CW (DXE) "tair"=35°C, 50%, "tc"=15/10°C	kW	70.35	104.93	127.71	173.35	225.26
Air flow rate	m <sup>3</sup> /h	10500	16200	19500	26500	35000
Depth	mm	865	865	865	865	865
Width	mm	1400	1750	2050	2550	3350
Height	mm	1970	1970	1970	1970	1970
Operating weight	kg	390	480	560	650	860
Power supply	V/ph/Hz	400/3/50	400/3/50	400/3/50	400/3/50	400/3/50
Connection dimensions						
Diameter of the refrigerant suction pipe (DXE)	mm	28	35	35	35	42
Diameter of the liquid refrigerant pipe (DXE)	mm	16	18	18	22	22
Diameter of chilled water pipe (CW)	inch	G1 $\frac{1}{4}$	G1 $\frac{1}{2}$	G1 $\frac{1}{2}$	G2	G2

ByteCOOL						
Type	DXR	DXR invi	DXW	DXW invi	DXE	CW
Compressor	●	-	●	-	-	-
Compressor with inverter	-	●	-	●	-	-
Compressor crankcase heater	●	●	●	●	-	-
Mounting kit	●	●	●	●	-	-
Cu-Al evaporator	●	●	●	●	●	-
Cu-Al air-water heat exchanger	-	-	-	-	-	●
Condenser (brazed plate heat exchanger)	-	-	●	●	-	-
EC fan	●	●	●	●	●	●
Air filter	●	●	●	●	●	●
EEV	○	●	○	●	-	-
Mechanical TEV	●	-	●	-	●	-
Oil separator with related components	○	●	○	●	-	-
Liquid line sight glass	●	●	●	●	●	-
Filter dryer	●	●	●	●	●	-
Solenoid valve	●	●	●	●	●	-
Solenoid valve coil	●	●	●	●	●	-
High pressure safety valve	●	●	●	●	-	-
Liquid line shut-off valve	●	●	●	●	●	-
Compressor discharge line shut-off valve	●	●	●	●	-	-
Compressor suction line shut-off valve	-	-	-	-	●	-
3-way valve	-	-	-	-	-	●
3-way valve actuator	-	-	-	-	-	●

## Note:

- - basic configuration
- (-) - not available
- - optional

ByteCOOL AUTOMATIC CONTROL						
Type	DXR	DXR invi	DXW	DXW invi	DXE	CW
Filter pollution sensor	●	●	●	●	●	●
"Fire alarm" signal	●	●	●	●	●	●
Built-in LCD display of the air conditioning unit	●	●	●	●	●	●
Incoming air temperature sensor	●	●	●	●	●	●
Outgoing air temperature sensor	●	●	●	●	●	●
Incoming water temperature sensor	-	-	-	-	-	●
Outlet water temperature sensor	-	-	-	-	-	●
High pressure switch	●	●	●	●	●	-
Low pressure switch	●	●	●	●	●	-
Pressure sensor on the suction line	●	●	●	●	●	-
Pressure sensor on the discharge line	●	●	●	●	●	-
Suction temperature sensor	-	●	-	●	-	-
Modbus RTU RS485 communication protocol	●	●	●	●	●	●

## Note:

- - basic configuration
- (-) - not available

ByteCOOL		DXR	DXR invi	DXW	DXW invi	DXE	CW
Options:		-	-	-	-	-	-
EEV	Electronic expansion valve	●	Basic	●	Basic	●	-
STG	Steam humidifier	●	●	●	●	●	●
HE	Electric heater	●	●	●	●	●	●
SSM	Smoke sensor	●	●	●	●	●	●
CPW	Condensation pressure monitoring for water-cooled air conditioners	-	-	●	●	-	-
SWL	Water leak sensor	●	●	●	●	●	●
BF	Base frame	●	●	●	●	●	●
CBP	Low-temperature kit	●	●	-	-	-	-
E2	Dual power input	●	●	●	●	●	●
CAR	Automatic load transfer	●	●	●	●	●	●
CFA	Fire alarm	●	●	●	●	●	●
PFO	Frontal distribution plenum	●	●	●	●	●	●

- The EEV has its own automatic control (EEV with actuator and emergency power module);
- The steam humidifier is used to create and maintain the required humidity level in the areas;
- The electric heater heats the indoor air;
- The smoke sensor reacts to smoke and activates an alarm;
- Condensation pressure control for water-cooled machines - 3-way valve for condensation pressure control of water-cooled machines;
- The water leak sensor helps to avoid water leakage;
- The base frame is used to place equipment in rooms with raised floors;
- The low-temperature kit increases the operating range of the air conditioner to -30 °C and to lower outdoor temperatures;
- The dual power input allows the unit to continue operating in the event of disconnection from a permanent power supply;
- Automatic load transfer for uninterrupted operation of air conditioners;
- The fire alarm activates warning devices in case of a fire hazard;
- A frontal distribution plenum is necessary for frontal air distribution.

ByteCOOL		DXR	DXR invi	DXW	DXW invi	DXE	CW
Options:		-	-	-	-	-	-
PFI	Frontal air intake plenum	●	●	●	●	●	●
AV	Air damper	●	●	●	●	●	●
SHM	Humidity sensor	●	●	●	●	●	●
FF5 / FF7	Filter class F5 / F7	●	●	●	●	●	●
CAR	Automatic load transfer	●	●	●	●	●	●
PWC	Grillage	●	●	●	●	●	●
WP	Drainage pump	●	●	●	●	●	●
WPH	High temperature drainage pump	●	●	●	●	●	●
LD	Leakage sensor	●	●	●	●	●	●
BN / LW	BACnet / LonWorks communication protocol	●	●	●	●	●	●
DPS	Dual power input	●	●	●	●	●	●
TS	Touch screen	●	●	●	●	●	●

- The frontal air intake plenum is necessary for the frontal air intake;
- The air damper controls the air flow;
- The humidity sensor allows monitoring the humidity level;
- The F5 filter is designed for medium air purification;
- F7 filter - a fine air filter traps particles larger than 1 microns.;
- ALT – automatic load transfer. This option allows for automatic switching to a backup power system when the main line is disconnected;
- A grillage is a rigid structure made of planks and timber that ensures the safety of the unit in its original form during transportation;
- A drainage pump is needed to drain condensate from the air conditioner;
- A high-temperature drainage pump for removing condensate from a steam humidifier unit;
- Leak sensor is a sensor of refrigerant leakage from the air conditioning system;
- BACnet card for connecting the unit via the BACnet data transfer protocol;
- LonWorks is a card for connecting an air conditioner using the LonWorks data transfer protocol;
- The dual power input consists of two independent power sources in an input and distribution device (IDD) for redundant power supply;
- The touch screen is a color touch screen with an intuitive interface.
- This section describes the main options. For any other options, please, contact your Felzer representative.

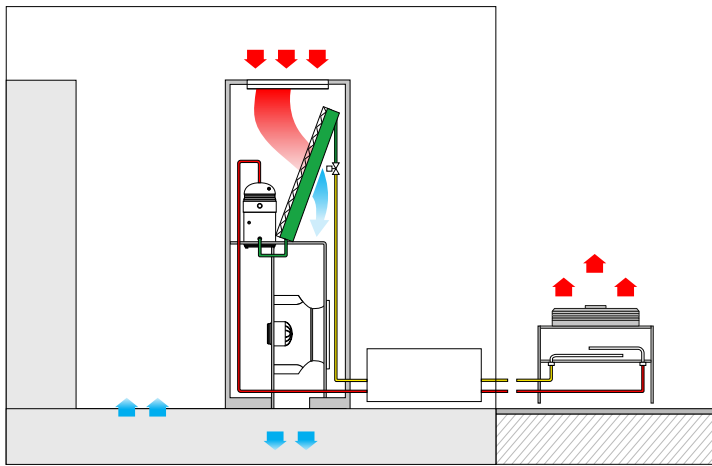

Felzer has developed a range of freestanding low-temperature modules. The low-temperature module is necessary to ensure trouble-free operation and facilitate the start-up of precision air conditioners when operating at low outdoor temperatures.

Low-temperature module										
	Unit	LTM001.5	LTM003	LTM004.5	LTM006.5	LTM010	LTM014	LTM021	LTM030	LTM045
Full cooling capacity	kW	4.5	6.6	7.4...8.1	9.6...18	18.7...29.2	30.8...34.4	38.4...54.4	49.3...72.6	85
Depth	mm	450	560	590	590	790	790	1150	1200	1400
Height	mm	300	460	480	530	500	560	400	420	440
Length	mm	350	380	380	410	410	410	410	430	450
Receiver volume	l	1.5	3	4.5	6.5	10	14	21	30	45
Connecting size										
Gas line	mm	12	16	16	16	22	22	28	28	28
Liquid line	mm	10	12	12	12	16	16	22	22	22

Standard size	ByteCOOL DXR(W)-U(D)	ByteCOOL DXR(W)I-U(D) – Inverter scroll compressor	ByteCOOL CW (DXE)-U(D)	Depth	Width	Height
IR300	IR300.061	IR300.051i	IR300	1200	300	1950
IR400	IR400.081	IR400.071i	IR400	1200	400	1950
IR600	IR600.101	IR600.091i	IR600	1200	600	1950

Note:

- Air parameters: 24°C (according to a dry thermometer), 50% relative humidity; condensation temperature 45°C.

## LTM\_001.5 (low temperature kit)

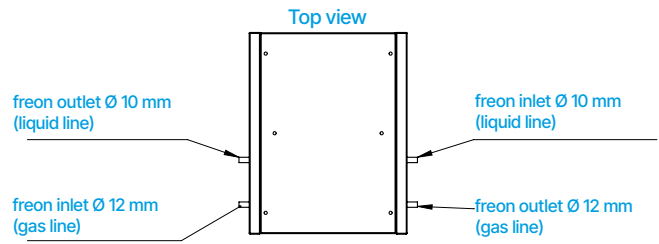
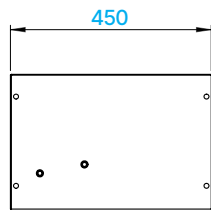
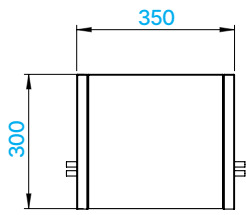

## LTM\_003 (low temperature kit)

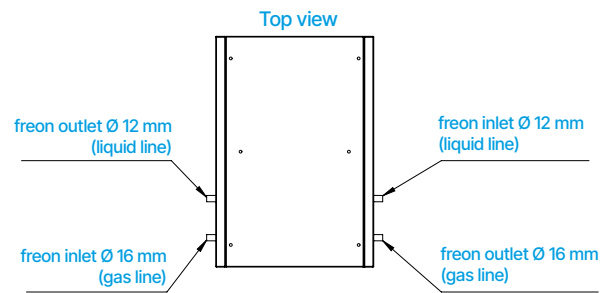
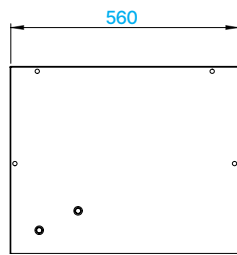
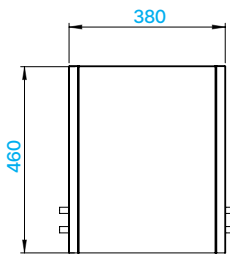

## LTM\_004.5 (low temperature kit)

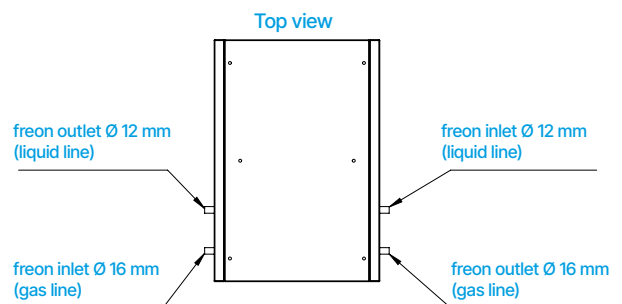
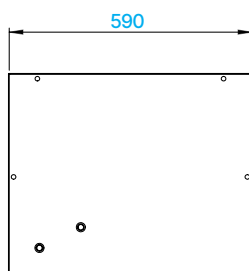
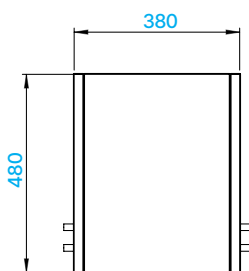

LTM\_006.5 (low temperature kit)

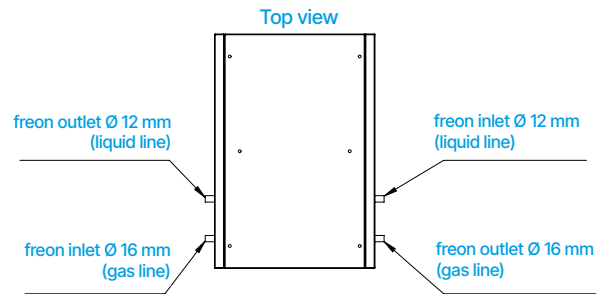
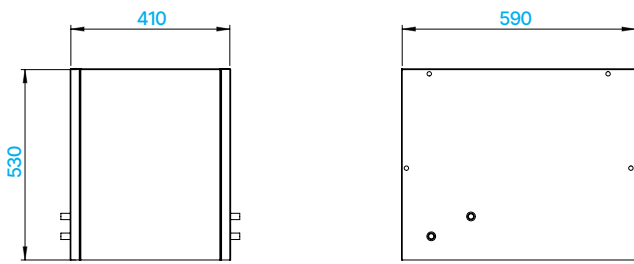

LTM\_010 (low temperature kit)

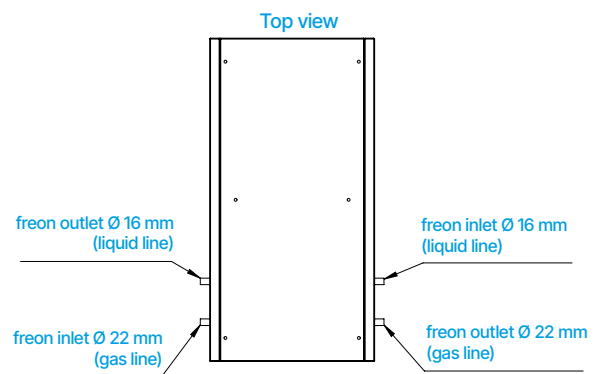
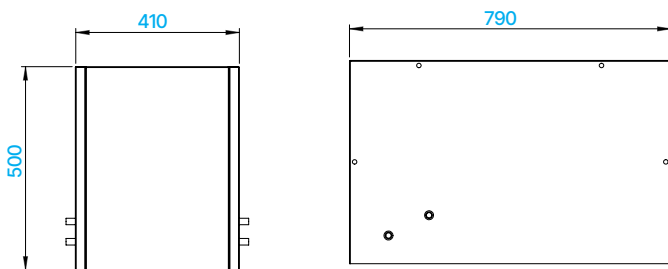

LTM\_014 (low temperature kit)

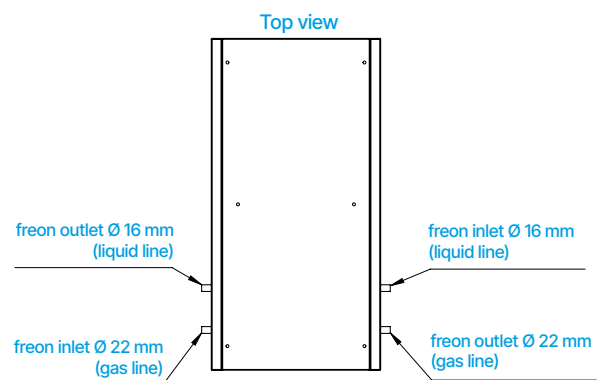
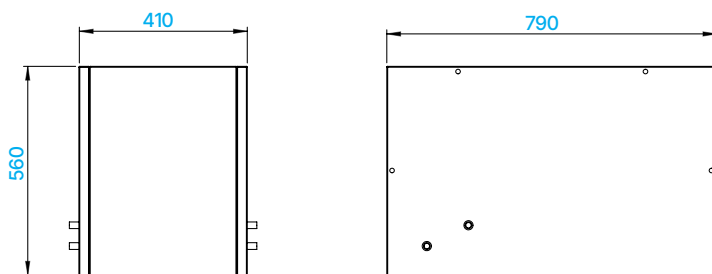

LTM\_021 (low temperature kit)

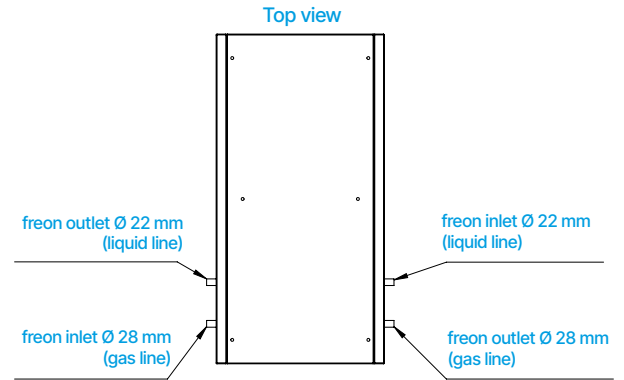
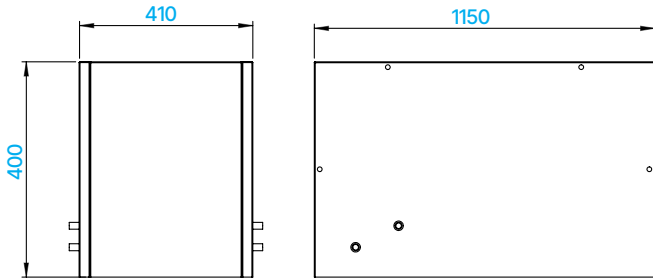

LTM\_030 (low temperature kit)

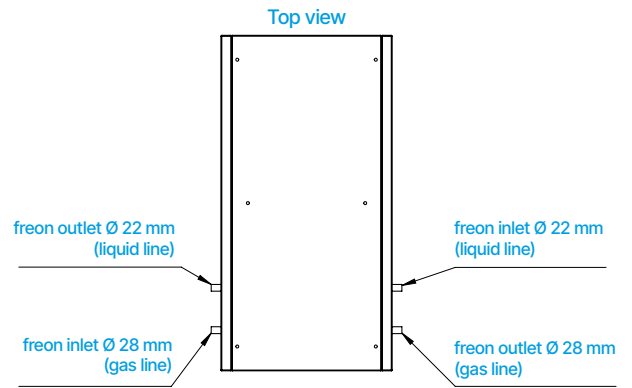
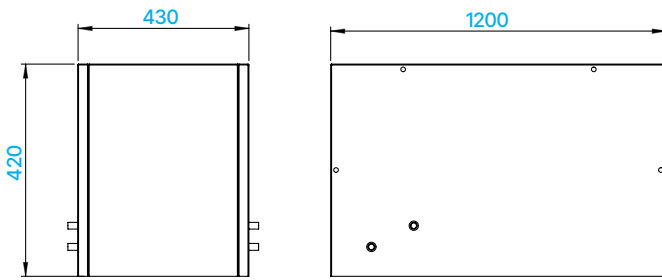

LTM\_045 (low temperature kit)

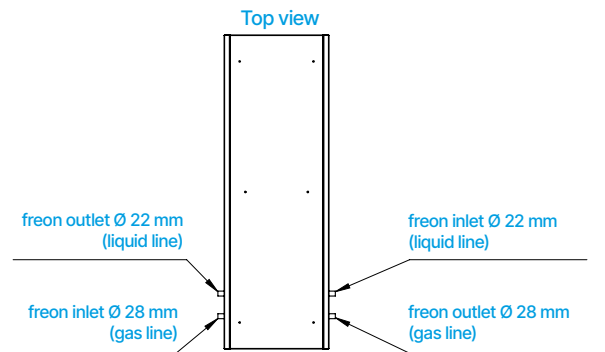
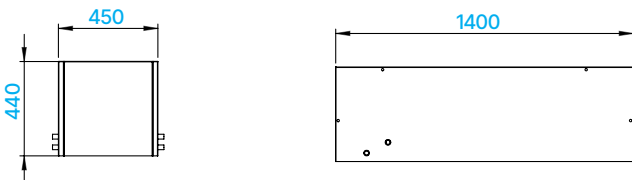

IR\_300  
IR\_400  
IR\_600

IN - ROW AIR CONDITIONERS  
PRECISION AIR CONDITIONERS

ByteCOOL IR\_300.061

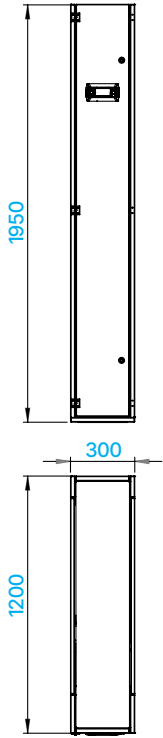

ByteCOOL IR\_400.081

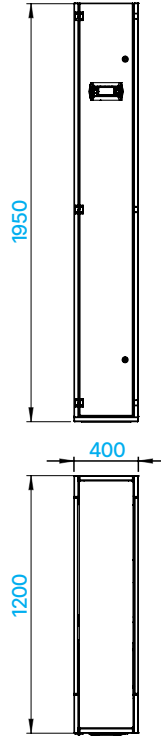

ByteCOOL IR600.101

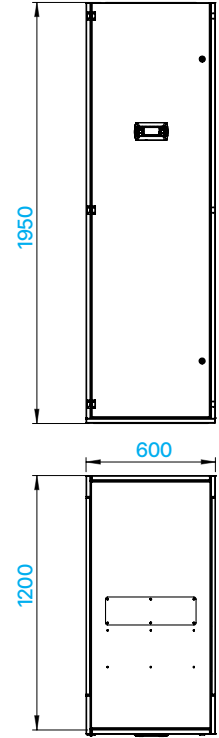

ByteCOOL L3350

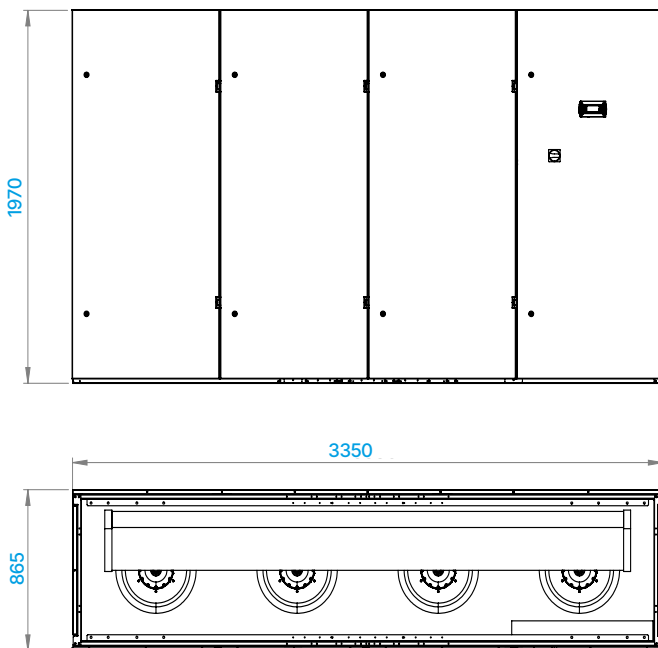

ByteCOOL\_S0600\_CW\_D

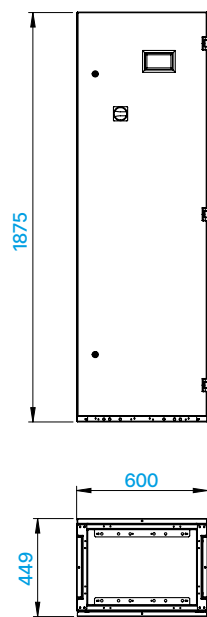

ByteCOOL\_S1200\_CW\_D

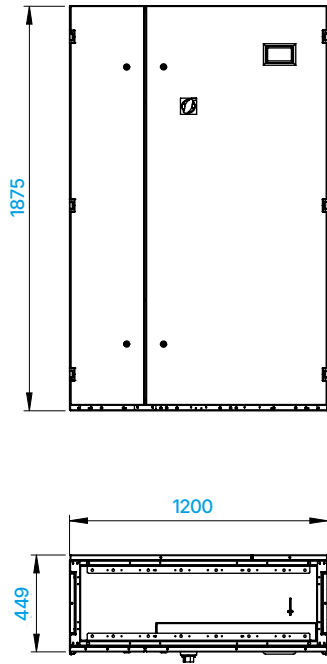

ByteCOOL\_S0850\_CW\_D

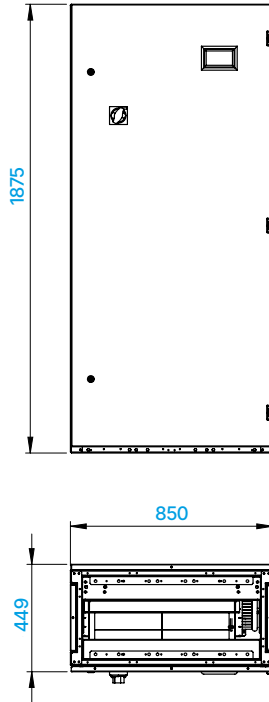

ByteCOOL L0850\_CW\_U

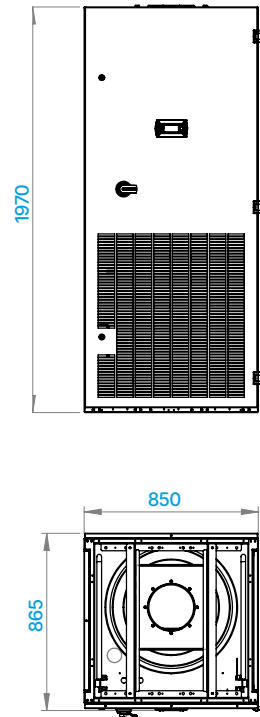

ByteCOOL\_L205\_SW\_D

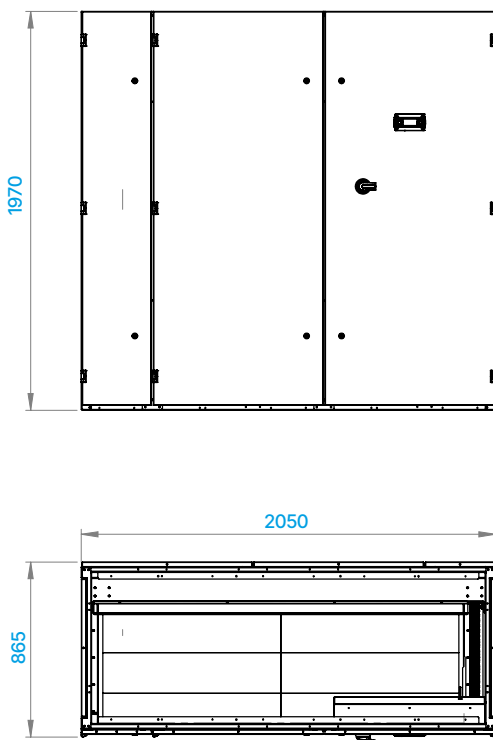

ByteCOOL L255 DXR

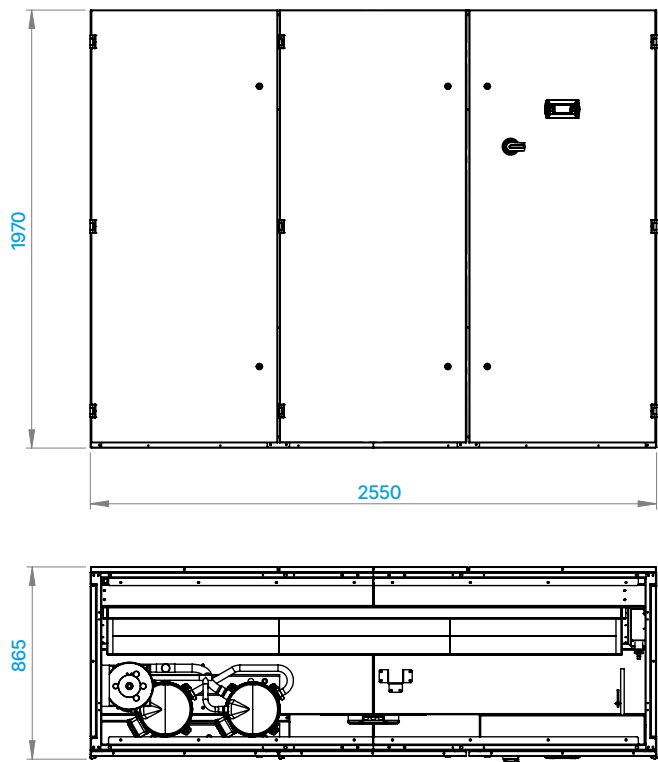

ByteCOOL\_L120\_DX\_D

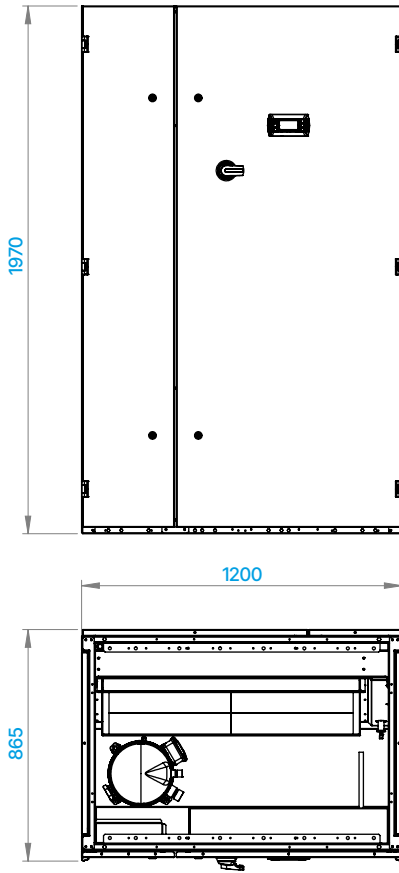

ByteCOOL L140\_DX\_D

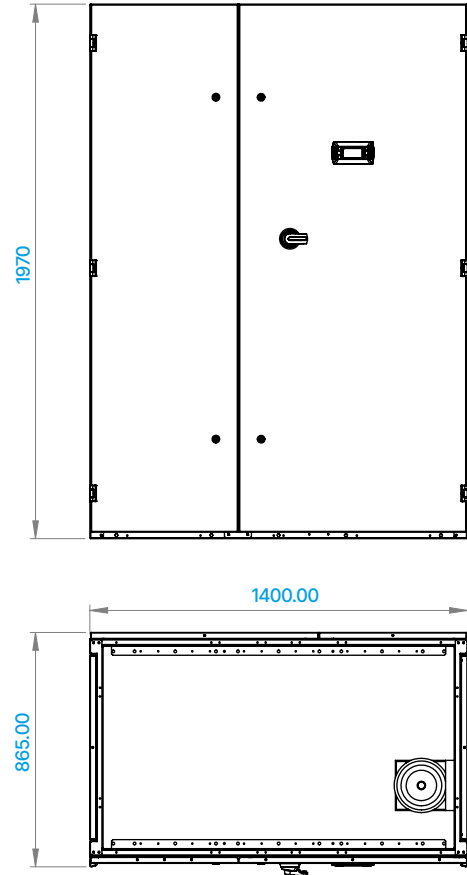

ByteCOOL L175\_DX\_D

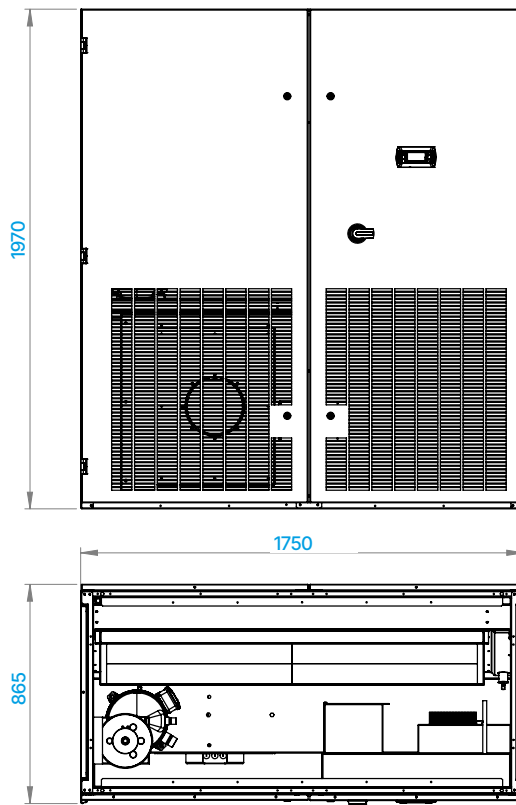

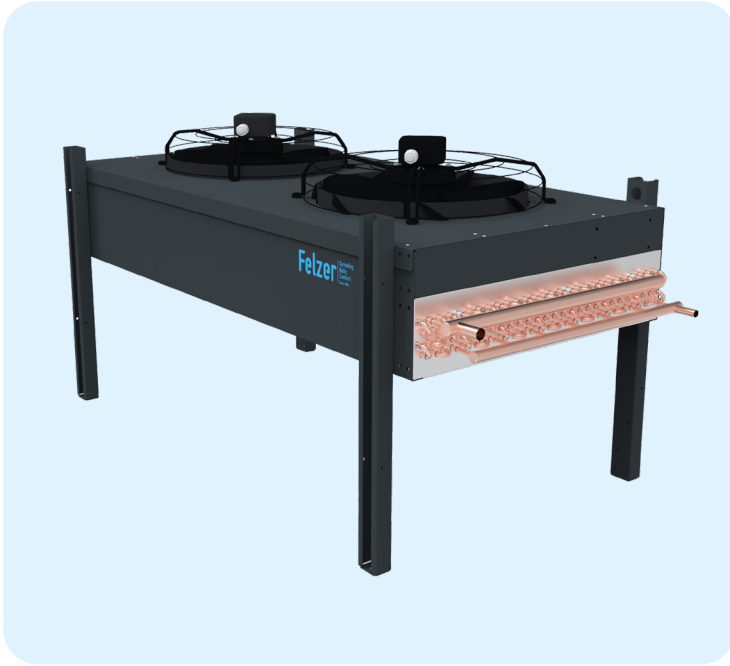

External condensers are not independent units for cooling air or water. This is part of the refrigeration cycle.

Condensers in the thermodynamic process perform the function of conversion of a refrigerant from a gaseous state to a liquid state.

The refrigerant is cooled by air in the case of remote condensers. The liquid refrigerant is piped back from the condenser to the precision air conditioner. The condensers can be retrofitted for efficient operation at outdoor temperatures from +40°C to -40°C. On special request, the operating range can be extended to -60°C.

## THE DESIGN OF THE REMOTE CONDENSER

### Strong frame

The frame prevents external mechanical impact on the heat exchanger and fans. It is painted with powder paint to protect against corrosion.

### Heat exchangers

Felzer provides several heat exchanger options for remote condensers of precision air conditioners: finned-tubular (Cu-Al) and microchannel. Each option has its advantages.

### Fans

Axial fans with IP 54 protection and thermal protection. The diffuser design and blade geometry increase efficiency and reduce noise levels.

### Electrical connection

The power supply of the remote condenser has a voltage of 230 V, single phase, 50 Hz. Optionally, a switch and a rotation speed controller can be provided to control condensation.

### Available options

Air-cooled condensers can be manufactured in various designs. They are classified according to various criteria.

#### Noise performance:

- Standard acoustic performance;
- Low-noise performance.

#### Air flow direction:

- Horizontal;
- Vertical.

## BN Cu-AI HEAT EXCHANGER

### REMOTE CONDENSERS

ByteCOOL BN (REMOTE CONDENSER)								
Standard size	Unit	008/35.2.1	011/35.4.1	015/45.4.1	022/35.4.2	24	31	46
Heating capacity at $\Delta T^*=18K$	kW	7.1	10.9	15.4	21.6	23.9	31	46
Heating capacity at $\Delta T=15K$	kW	5.99	9.19	12.98	18.21	20.15	26.05	38.78
Heating capacity at $\Delta T=12K$	kW	4.47	7.27	10.27	14.41	15.94	20.61	30.68
Air flow rate	m <sup>3</sup> /h	2520	2268	4032	4572	7632	7272	13896
Depth	mm	440	440	440	440	440	440	440
Height	mm	550	550	750	550	750	750	750
Length	mm	600	600	833	1065	1530	1530	1530
Power supply	V/ph/Hz	230/1/50	230/1/50	230/1/50	230/1/50	230/1/50	230/1/50	230/1/50
Number of circuits	pc	4	10	18	20	16	32	26
Operating weight	kg	45	50	65	75	110	116	120
Recommended low-temperature module	-	LTM001.5	LTM003	LTM004.5	LTM006.5	LTM006.5	LTM010	LTM010

#### Note:

- \* $\Delta T$  is the difference between the air temperature and the condensation temperature. For example, if the air temperature is 32°C and the condensation temperature is 50°C, then  $\Delta T=18$  K.

ByteCOOL BN (REMOTE CONDENSER)								
Standard size	Unit	55	70	75	83	100	121	140
Heating capacity at $\Delta T^*=18$	kW	55.2	68	74.3	81.1	98	121	140
Heating capacity at $\Delta T=15K$	kW	46.53	57.32	62.63	68.37	82.61	102	118.02
Heating capacity at $\Delta T=12K$	kW	36.82	45.36	49.56	54.09	65.37	80.72	93.38
Air flow rate	m <sup>3</sup> /h	13284	15372	14652	18360	18396	31644	27576
Depth	mm	440	480	480	500	500	500	500
Height	mm	750	850	850	1050	1050	1050	1050
Length	mm	1530	1750	1750	2160	2160	3160	3160
Power supply	V/ph/Hz	230/1/50	230/1/50	230/1/50	230/1/50	230/1/50	230/1/50	230/1/50
Operating weight	kg	130	150	160	180	200	210	225

#### Note:

- \* $\Delta T$  is the difference between the air temperature and the condensation temperature. For example, if the air temperature is 32°C and the condensation temperature is 50°C, then  $\Delta T=18$  K.

## ByteCOOL MC MICRO-CHANNEL HEAT EXCHANGER

REMOTE CONDENSERS

ByteCOOL MC (REMOTE CONDENSER)							
Standard size	Unit	15	17	18	19	201	202
Heating capacity at $\Delta T^*=18K$	kW	22.76	35.62	54.83	74.16	94.68	189.36
Heating capacity at $\Delta T=15K$	kW	18.78	29.5	45.3	61.34	78.32	156.64
Heating capacity at $\Delta T=12K$	kW	15.09	23.25	35.33	48.64	62.09	124.18
Air flow rate	m <sup>3</sup> /h	4997	7614	11725	15628	19044	38088
Depth	mm	600	720	1155	1355	1140	1230
Height	mm	1030	1025	1125	1125	1165	1550
Length	mm	1165	1415	1305	1455	2090	2220
Power supply	V/ph/Hz	230/1/50	230/1/50	230/1/50	230/1/50	230/1/50	230/1/50

Note:

- The technical parameters are given taking into account the air temperature: 32°C, condensation temperature 50°C.

## BN FINNED-TUBULAR HEAT EXCHANGER

### REMOTE CONDENSERS

#### SIDE FLOW

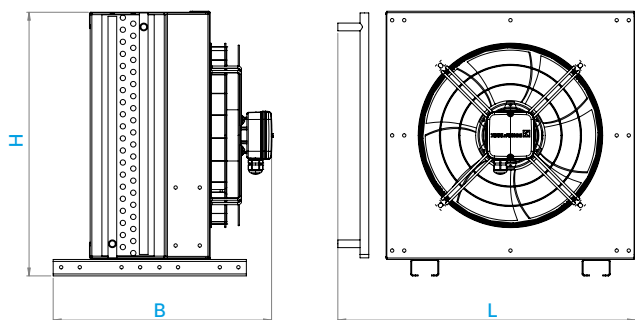

Standard size	Unit	L	B	H
BN008-BN011	mm	600	440	550
BN15	mm	833	440	750

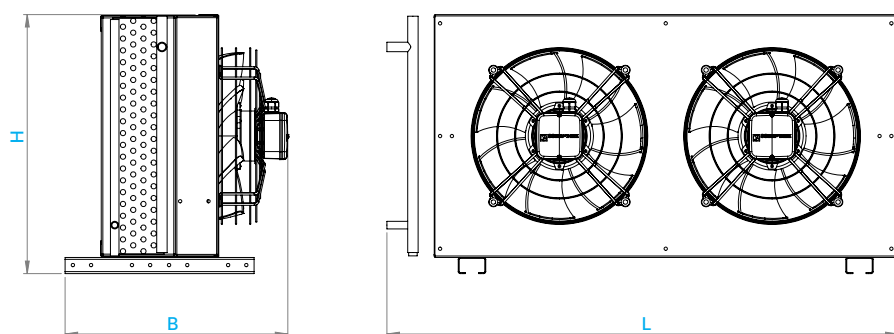

Standard size	Unit	L	B	H
BN22	mm	1065	440	550
BN24-BN55	mm	1530	440	750
BN70-BN75	mm	1750	480	850
BN83-BN100	mm	2160	500	1050

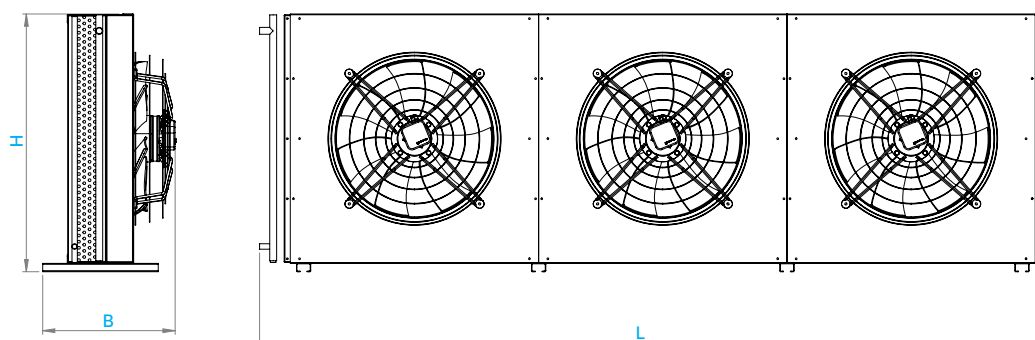

Standard size	Unit	L	B	H
BN121-BN140	mm	3160	500	1050

## BN WITH FINNED-TUBULAR HEAT EXCHANGER

REMOTE CONDENSERS

TOP FLOW

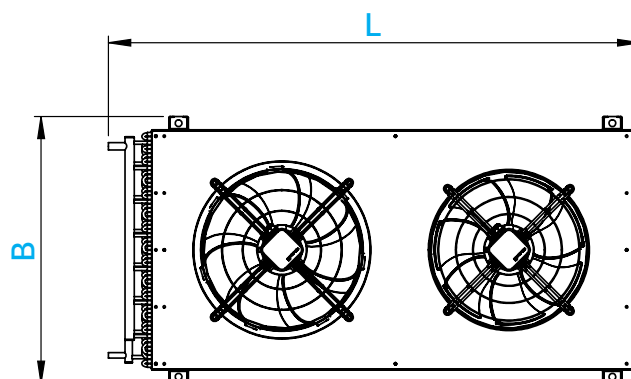
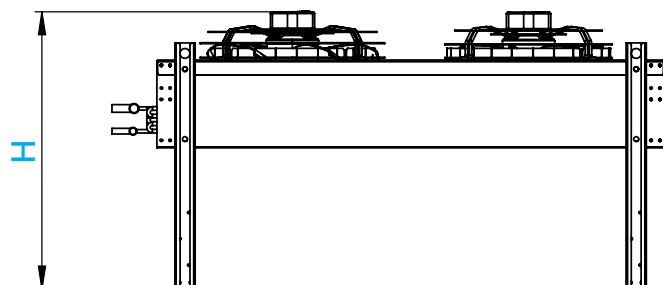

Standard size	Unit	L	B	H
BN008-BN011	mm	600	600	790
BN015	mm	835	600	790
BN22	mm	1065	600	800
BN24-BN55	mm	1530	800	800
BN70-BN75	mm	1750	900	900
BN83-BN100	mm	2160	1100	935
BN121-BN140	mm	3160	1100	935

## MC WITH MICRO-CHANNEL HEAT EXCHANGER

### REMOTE CONDENSERS

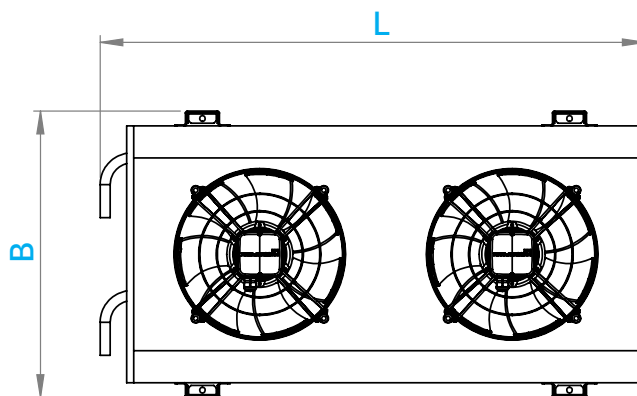
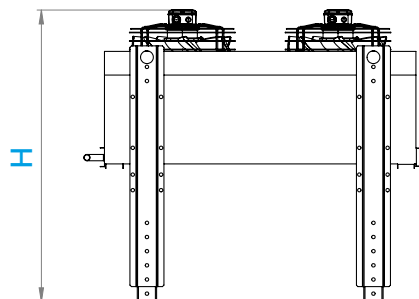

Standard size	Unit	L	B	H
MC15	mm	1165	600	1030
MC17	mm	1415	720	1025
MC18	mm	1305	1155	1125
MC19	mm	1455	1355	1025

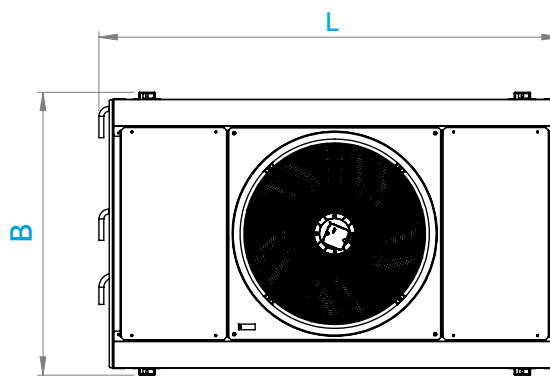
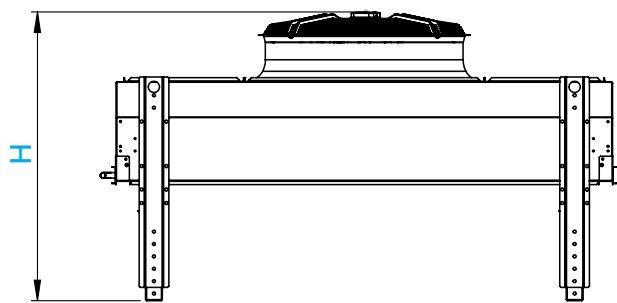

Standard size	Unit	L	B	H
MC201	mm	2090	1140	1165

## MC WITH A V-SHAPED MICROCHANNEL HEAT EXCHANGER

REMOTE CONDENSERS

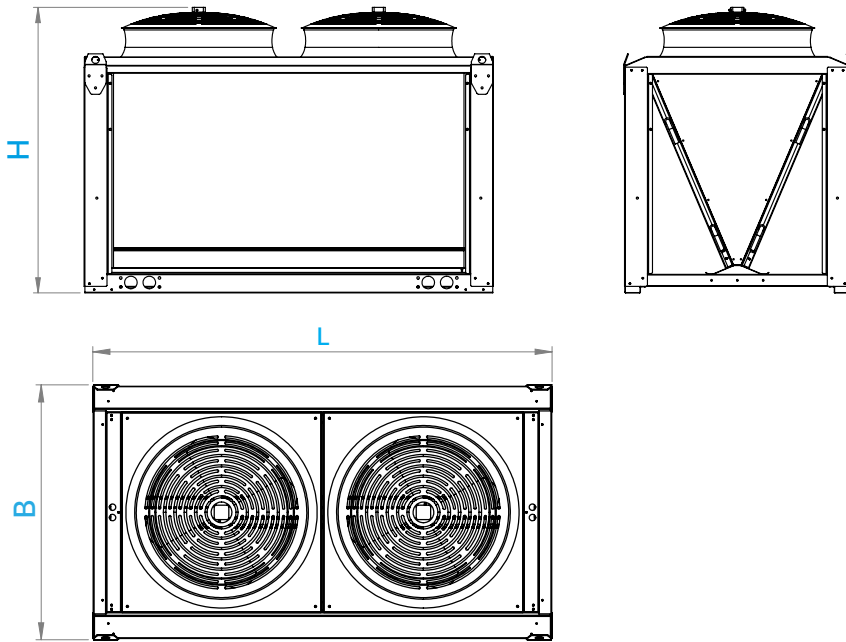

Standard size	Unit	L	B	H
MC202	mm	2220	1230	1550



Felzer SIA  
Brivibas gatve, 201  
Riga, Latvia, LV-1039  
tel: +371 230 05 545  
sales@felzer.lv  
www.felzer.lv

Felzer is continuously improving its products. We therefore reserve the right to change the design and specifications without prior notification.

Rights reserved. Felzer and the Felzer logo are registered trademarks of Felzer SIA. All trademarks to which reference is made herein are the property of their owners.

© Felzer SIA